

VAS 6230A Road Force Measurement® System

Customized for all Audi and Volkswagen Vehicles



***Solves vibration and
tire-pull problems that
balancers and
aligners cannot fix.***

Winner of Three



HUNTER
Engineering Company

VAS6230A

Going far beyond the



VAS6230A shown with factory installed Wheel Lift option (VAS6230A/2).



Hunter's exclusive Road Force Measurement® system simulates a road test to identify radial-force vibration and pull problems.

Benefits of the

■ Solves Vibration Problems Balancers Cannot Fix

Detects non-balance, radial-force-related problems associated with:

- Tire uniformity.
- Tire and rim runout.
- Wheel-to-balancer mounting error.
- Improper bead seating of tire to rim.

* Patented

traditional functions of a wheel balancer...

The VAS6230A measures radial and lateral tire forces and provides instructions for solving ride and handling problems that balancers and wheel aligners cannot fix.

Hunter's VAS6230A is approved workshop equipment that has been customized for all Audi, Bentley, Seat, Skoda and Volkswagen vehicles and proven by thousands of repair facilities worldwide as the industry standard in...

- 1. Wheel Balancing.**
- 2. Tire Road Force and Rim Eccentricity Measurement.**
- 3. Tire-Pull Lateral-Force Measurement.**



Visit The
Hunter
Wheel Balancing
Consumer and
Technical Website
www.gsp9700.com

VAS6230A's "Three-In-One" Diagnostic Repair Capability:

■ Faster Troubleshooting & Repair

Quickly calculates the contributions of the rim and tire to radial vibration problems and presents the technician with easy step-by-step repair instructions.

■ Identifies Potential Vehicle Pull or Drift Problems

The StraightTrak® LFM* feature measures lateral tire force, then applies that information to the set of tires, providing multiple placement choices to eliminate or minimize pull problems—an otherwise unfixable vehicle complaint during alignment service.

■ Dramatically Improves Ride Quality & Customer Satisfaction

Duplicates vibration measurement and tire/wheel matching methods previously used only by vehicle manufacturers to provide that "new car ride."

■ Increases Wheel Service Income

Establishes your shop as **the** vibration and handling control experts. Reduces comebacks and enables you to service vehicles that other shops turn away.

Road Force® Measurement



VAS6230A's Inflation Station* provides proper inflation pressure and automatic prompting for the operator to ensure accurate testing and customer satisfaction.

The exclusive Road Force Measurement® system applies up to 1,400 pounds (635 kg) against the tire. The loaded roller detects non-balance, radial-force-related vibrations caused by eccentricity and constructional variation of the tire and wheel. Unlike non-contact measurement, the roller samples the entire footprint of the tire including the sidewall's contribution to ride quality.

As an additional alternative to Road Force® mode, the operator may also choose a QuickMatch® mode to quickly measure loaded runout alone.

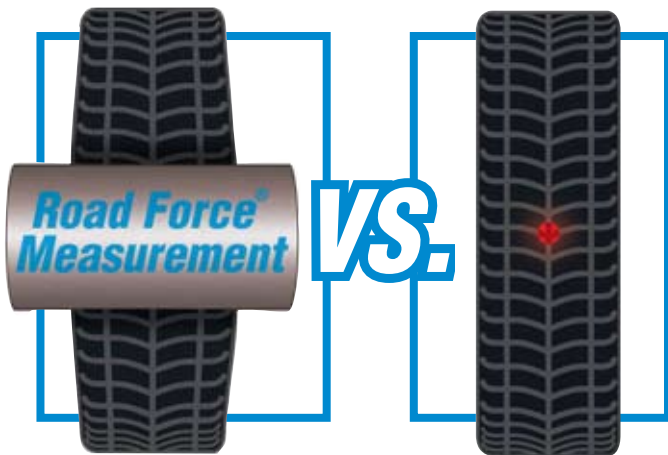
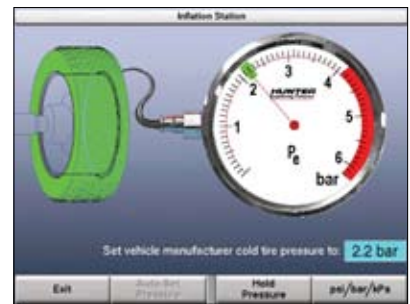

Non-contact runout measurement systems often provide inconsistent results and do not take into consideration the contribution of tire sidewalls to vibration problems.

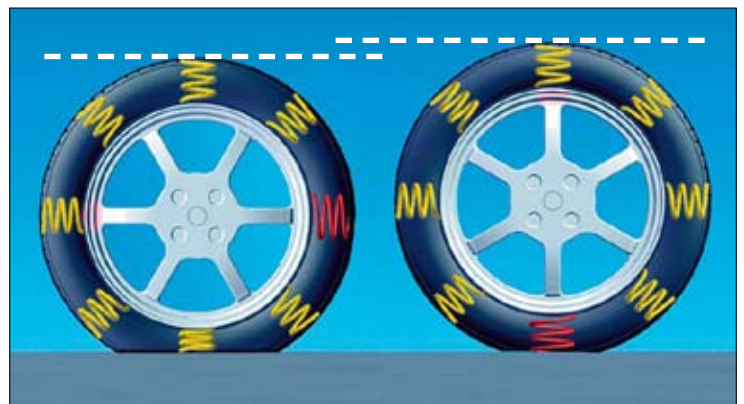

Lack of tire uniformity is a common and often hidden source of vibration. As a tire rolls, it flexes as if it were made of springs. Vibration results when tire stiffness is not uniform.

* Patented

Rim Runout Measurement



VAS6230A shown with optional printer and printer support kit (VAS6230A/1) and factory installed wheel lift option (VAS6230A/2).



Rim runout can be measured without removing the tire...



... or directly at the bead seat on a bare rim.

The VAS6230A measures lateral and radial rim runout without removing the tire from the rim and quickly indicates if runout is tire-related. Runout can also be measured at the actual bead seat on a bare rim.

The VAS6230A slowly rotates the wheel automatically during measurement.* The VAS6230A then calculates the contributions of the tire and the rim to the vibration problem and presents the technician with easy-to-follow repair instructions.

Slippage detection is also automatically monitored to ensure the technician achieves accurate measurements.

Integrated Wheel Lift System Increase Productivity and Improve Accuracy

Hunter's optional integrated Wheel Lift System helps technicians safely service today's oversized custom, light-truck and medium-duty commercial wheels quickly and easily.

(Wheel Lift option must be ordered with the machine and cannot be added as an upgrade to existing units in the field. Order VAS6230A and VAS6230A/2.)

Benefits:

- Helps reduce operator fatigue.
- Helps center heavy wheels up to 175 lbs. (80 kg) more accurately for better balancing results.
- Saves valuable workspace on the shop floor and avoids the excessive costs associated with bulky stand-alone wheel lift units.
- "Drop-away" feature automatically lowers the lift when the hood is closed – eliminates procedural steps associated with stand-alone wheel lift units.



* Patented feature

ForceMatching and Balance



Hunter's patented ForceMatching® feature cancels the stiffest point of tire radial-force variation with the low spot on the rim. This helps eliminate vibration by minimizing the effects of radial-force variation and rim runout.

QuickMatch® measurement may also be chosen to quickly audit and match-mount with loaded runout instead of force calculations if greater time savings during cycle time is preferred.

Once the correction is completed, the technician can continue with a precision wheel balance by instantly choosing the balancing method without key closure steps.

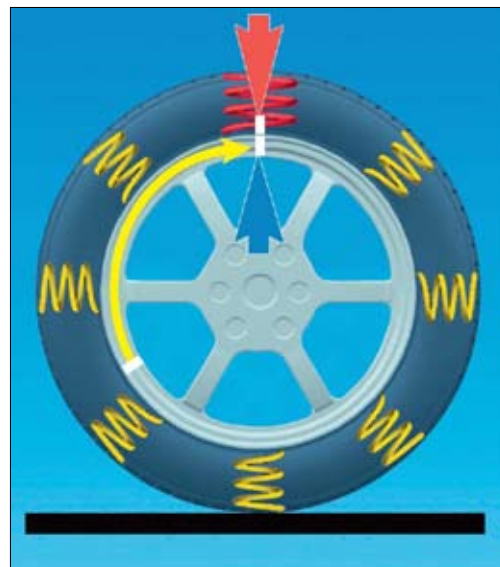

Offering the same service as new car vehicle manufacturers, the VAS6230A matches the stiffest area or high spot on the tire with the lowest spot on the rim to cancel vibration caused by radial-force variation and provide the smoothest possible ride.

StraightTrak® Lateral Force Measurement

Solve Tire-Pull Problems With the Hunter VAS6230A That Alignment Service Can't Fix

Tire-related pulls are caused by lateral forces in the tires. Lateral force is the amount of left or right pull force created as the tire rolls along the road. This condition may cause a vehicle to steer away from straight ahead. These forces are primarily created by conicity and cannot be detected during standard balancing or alignment service.

Deliver the Ultimate in Customer Satisfaction

The StraightTrak® LFM feature measures lateral tire force during the VAS6230A's Road Force Measurement® test. The VAS6230A then applies this lateral force information to the set of tires, providing the technician with optimal placement choices about the vehicle.

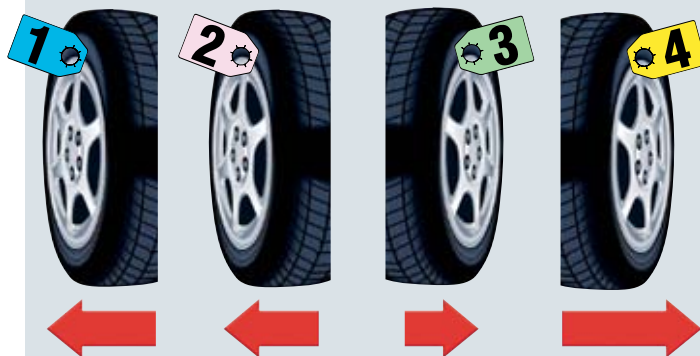
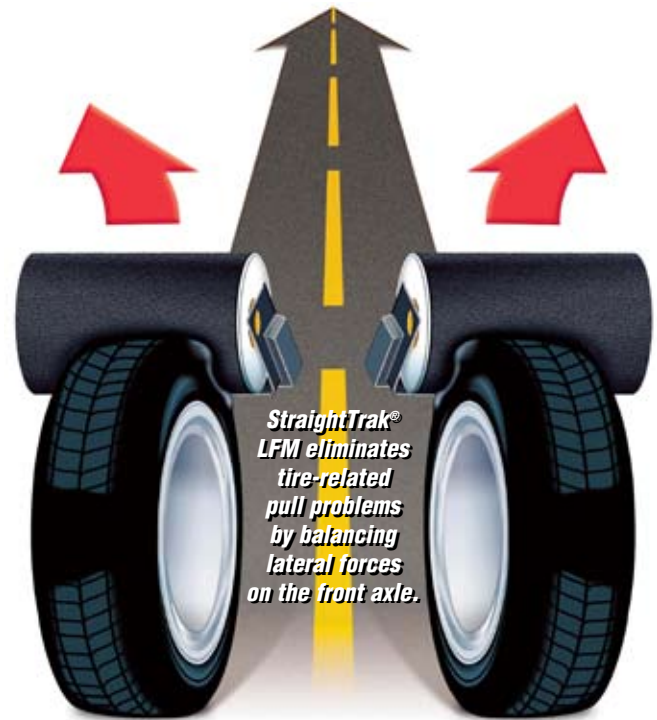

Tires are tagged and positioned on the vehicle to provide the least amount of vehicle pull and obtain the best straight-steering stability.

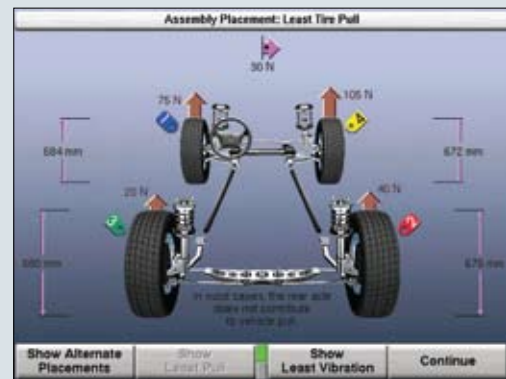

Pull or drift caused by the lateral forces can be systematically minimized, offset or eliminated.



StraightTrak® LFM Integration

By partnering a StraightTrak LFM equipped VAS6230A with a Hunter VAS6292 or VAG1944 wheel alignment system, the technician will finally be able to deliver the ultimate in customer satisfaction by achieving the four main wheel service criteria customers expect in vehicle ride quality:

- Proper tire wear.
- Straight vehicle tracking.
- Smooth ride.
- Straight steering wheel.

For more information on StraightTrak LFM, ask your Hunter Sales Representative for Form 4863T or for the demo video, Form 4879T.

SmartWeight® Balancing Technology

- Reduces wheel weight costs 30% to 40%
- Significantly reduces labor costs and service time
- Simplifies balancer use
- Eliminates shortcuts that affect quality
- Automatically performs a better overall balance



Hunter Engineering's patented SmartWeight® balancing technology is a revolutionary wheel balancing method that minimizes correction weight usage and maximizes productivity, saving money on both material and labor costs. SmartWeight balancing technology can **reduce wheel weight costs 30% to 40%**, reduce the time it takes to balance most wheels, and improve vehicle ride quality!

This new method computes correction weights by measuring and evaluating the "absolute" or pure static (shake) and couple (shimmy) forces that cause vibration. Unlike traditional balancing, which judges balance conditions based on correction weight values, SmartWeight balancing uses the actual static and couple forces to directly address the source of vibration problems, resulting in the best possible balance. The VAS6230A can be set up to have SmartWeight balancing enabled or disabled.

Save Labor Time on More Than 30% of Balances!

SmartWeight technology typically reduces "floor-to-floor" cycle time on more than 30% of wheels balanced by using a single wheel weight instead of two to correct static and couple imbalance.

With many assemblies, SmartWeight technology enables the technician to use only a single weight to achieve the best possible static and couple balance.

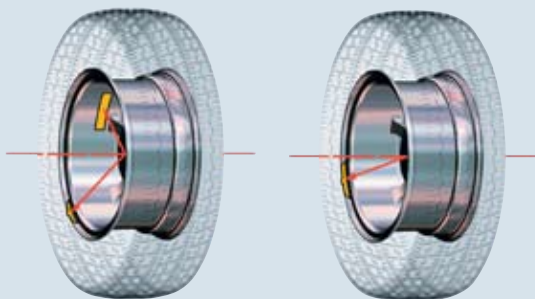

Typical Double Weight Correction

Single Weight Correction with SmartWeight Technology

Weight Savings							
	cc-14"	15"-17"	18"-20"	21"-23"	24"->"	Total	
Clip-Clip	Splice	36	30	4	4	0	64
	Non-SmartWT	3429	1768	288	288	0	5728 g
	SmartWT	2439	1305	235	210	0	4189 g
	Savings	990	465	45	58	0	1540 g
	T wt req'd	11	7	3	1	0	22
	no wts req'd	3	1	1	0	0	5
Clip-Tape	Splice	0	0	0	4	0	39
	Non-SmartWT	0	1640	1485	585	0	3628 g
	SmartWT	0	1065	1019	425	0	2509 g
	Savings	0	575	395	160	0	1130 g
	T wt req'd	0	3	5	1	0	9
	no wts req'd	0	2	1	0	0	3
Tape-Tape	Splice	0	16	12	4	4	36
	Non-SmartWT	0	3335	1850	745	388	6318 g
	SmartWT	0	1999	1185	510	275	3969 g
	Savings	0	1345	665	230	105	2349 g
	T wt req'd	0	5	3	1	2	11
	no wts req'd	0	1	0	0	0	1
						Totals	Splice: 120
							Non-SmartWT: 15668 g
							SmartWT: 10615 g
							Savings: 5053 g
							T wt req'd: 42
							no wts req'd: 8

Easily View Weight Savings on the Balancer Screen!

SmartWeight balancing software displays and stores wheel weight savings for each balance cycle. Cumulative weight savings can be displayed and printed, making it easy to record and track wheel weight savings over time.

This example shows that for 120 wheels, SmartWeight technology saved a total of 5015 grams (32%) of weight. Labor time was also reduced, because 35% of the wheels were dynamically balanced with only one weight.

Features That Make Expert Balancing Easier and Faster...

HammerHead™ TDC Clip-On Weight Locator Laser



The ServoDrive activated laser lines automatically identify the “Top-Dead-Center” position to assist with fast clip-on weight placement. The system helps to increase balance accuracy, productivity and shop profitability. The HammerHead™ feature ensures weight attachment accuracy resulting in more single-spin balances and superior ride satisfaction. The fluorescent light also illuminates the operator’s work area.

Ordering Information

The HammerHead feature can be added as an option by ordering part number 20-2166-1.

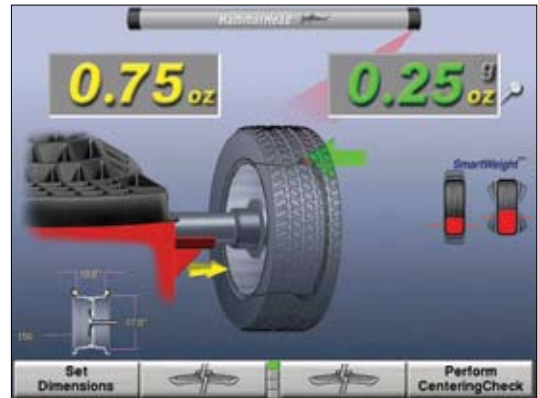

The ServoDrive activated laser lines are projected onto the rim flange when the wheel weight position is located.

Clip-Weight Placement



Precision wheel weight placement is fast and easy using the TDC laser as a guide.



HammerHead TDC Laser reduces weight placement errors by eliminating misjudgment of the TDC position, which often occurs using other methods. Such visual errors lead to an inferior and time-consuming balance with numerous checkspins.

Features That Make Expert Balancing Easier and Faster...

SmartSpoke™ Locator Feature

Derived from SmartWeight® balancing, the SmartSpoke™ weight locator feature enables the technician to achieve the best possible balance by placing only a single adhesive weight behind one wheel spoke instead of two weights behind two spokes. This feature reduces weight use, minimizes labor time and speeds the balance procedure.



The SmartSpoke balancing feature resulted in less weight used and reduced service time.



Without the SmartSpoke feature more weight and time is used.

Automatic Weight Mode Detection**

Balance mode is selected automatically based on the position chosen for the Inner Dataset® arm or Outer Dataset® arm.

This feature eliminates the need for the technician to select balance mode, reducing time-consuming key closures and possible mode entry errors. No need for multiple balance mode choices or PAX wheel system programs.



When the technician places the Inner Dataset® arm up on the wheel rim, the balancer automatically selects the "Clip Weight Mode."



When the technician places the Inner Dataset® arm down inside the wheel, the balancer automatically selects the "Tape Weight Mode."

BDC Adhesive Weight Placement Laser

- ServoDrive-activated laser line automatically identifies the "Bottom-Dead-Center" position to assist with fast adhesive weight application.
- Helps guide operator to optimal location for correct weight placement for accurate phase angle.



Split Spoke® & Split Weight® Modes*

- Split Spoke® mode automatically locates the best "out of sight" position for adhesive weight placement on custom wheels.
- Split Weight® mode offers multiple weight choices, reduces inventory of large weights and avoids trim ring obstructions



AutoClamp Feature*



The optional AutoClamp feature saves time and effort. The clamp adaptor is positioned and tightened automatically. There are no time-consuming shaft threads to take up and no additional wing nut tightening required. (Pneumatic AutoClamp option must be ordered with the machine and cannot be added as an upgrade to existing units in the field. Order VAS6230A and VAS6230A/3.)

Automatic Double Dataset® Arms



Inner and Outer Dataset® arms speed entry of exact chosen weight location and double as measuring tools for lateral and radial runout. Speeds placement of clip-on or adhesive weights while increasing accuracy and single-spin balances.

Rim Scan Feature



The Inner Dataset® arm will trace the exact wheel contour and stores the scanned distances and diameters across the entire available tape weight locations selected by the operator. Also offers the benefits of Automatic Weight Positioning to increase the capability to single spin balance with SmartWeight technology.

Instant Foot Pedal Data Entry



- Tapping the foot brake activates entry and storage of wheel data.
- Foot pedal also locks spindle for easier tightening and loosening of wing nut.

Servo Stop and Servo Push Drive Control*



Servo Stop automatically rotates and positions wheel to each desired weight location (TDC or BDC) with the touch of a button or by simply pushing the wheel.

Wheel CenteringCheck® Feature*



This feature, **exclusive** to Hunter wheel balancers, ensures that the wheel is properly centered when mounted on the balancer. Uniquely eliminates guesswork when choosing mounting accessories or questioning set-up error on problematic wheels.

VAS 6230A Road Force Measurement® System

Specifications†

Power Requirements:	230 V (+10% -15%), 10 amp, 50/60 Hz, 1-ph (Power cable includes NEMA 20 amp plug, L6-20P)
Air Supply Requirements:	100-175 psi (7-12 bar)
Motor:	Programmable drive system and DC motor**
Shipping Weight:	Without Wheel Lift: 302 kg (664 lbs.) With Wheel Lift: 323 kg (711 lbs.)
Roller Force:	Variable up to 635 kg (1,400 lbs.)
Capacity:	
Rim Width:	38 mm (1.5 in.) to 520 mm (20.5 in.)
Rim Diameter:	254 mm (10 in.) to 762 mm (30 in.)
ALU:	191 mm (7.5 in.) to 1016 mm (40 in.)
Maximum Tire Diameter:	1,016 mm (40 in.)
Maximum Tire Width:	508 mm (20 in.)
Maximum Tire Weight:	80 kg (175 lbs.)
Accuracy:	
Radial & Lateral Runout:	0.05 mm (0.002 in.)
Radial Force Measurement:	1.0 kg, 9.8N (2.2 lbs.)
Imbalance Resolution:	± 1.0 gms (± 0.05 oz)
Placement:	512 positions, ± 0.35°
Balancing Speed:	Variable rpm, direction and torque (0-300rpm)
Certification:	C.E., PTB, DIN IEC 38

†Some dimensions, capacities and specifications may vary depending on tire and wheel configuration.



VAS6230A shown with factory installed Wheel Lift option (VAS6230A/2).

VAS6230A Dimensions (shown with optional Wheel Lift and optional HammerHead feature)

A 254 mm (10 in.)	D 1854 mm (73 in.)
B 1562 mm (61.5 in.)	D1 2184 mm (86 in.)
B1 1041 mm (41 in.)	E 1435 mm (56.5 in.)
B2 1473 mm (58 in.)	E1 1676 mm (66 in.)
C 1575 mm (62 in.)	F 1626 mm (64 in.)

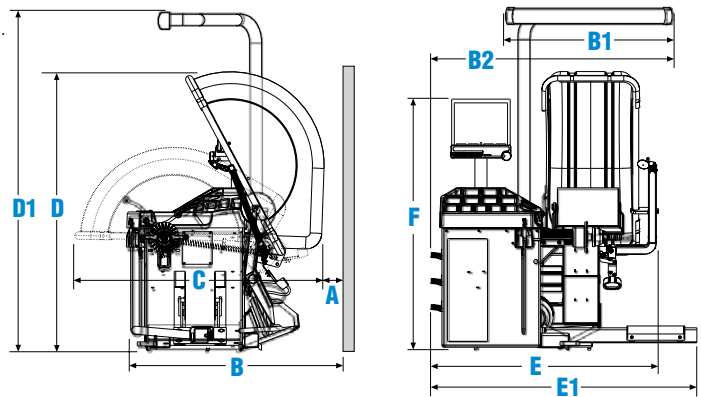

Feature	Domestic VW-AUDIVAG 6230A Models			
	GSP972205VAG	GSP972207VAG	GSP972305VAG	GSP972307VAG
Clamping System	Wing Nut w/ Handles	Wing Nut w/ Handles	Auto Clamp	AutoClamp
Wheel Lift		X		X
Road Force® Measurement	X	X	X	X
StraightTrak® Tire Pull Measurement	X	X	X	X
Precision Adaptor Kit, 20-2154-1	X	X	X	X
Calibration Tools	X	X	X	X
Ink Jet Printer	X	X	X	X

Because of continuing technological advancements, specifications, models and options are subject to change without notice.

CenteringCheck®, Dataset®, ForceMatching®, HammerHead®, MatchMaker®, QuickMatch®, Quick-Thread®, Road Force Measurement®, Smart Spoke®, SmartWeight®, Spindle-Lok®, Split Spoke®, Split Weight®, StraightTrak® and WeightSaver® are trademarks of Hunter Engineering Company.



LASER LIGHT
DO NOT STARE INTO THE BEAM OR VIEW
DIRECTLY WITH OPTICAL INSTRUMENTS
CLASS 2M LASER PRODUCT

LASER LIGHT
DO NOT VIEW DIRECTLY
WITH OPTICAL INSTRUMENTS
CLASS 1M LASER PRODUCT

Visit our Website: www.hunter.com
HUNTER
Engineering Company

11250 Hunter Drive, Bridgeton, MO 63044 U.S.A.
Tel: 1-314-731-3020 • Fax: 1-314-731-0132
E-mail: international@hunter.com

For optional accessories request Hunter Form 3203T.

* Patented ** Patent Pending