

Revolution™ Tire Changer

Fully Automatic and Easy-to-Use

NEW!



MADE IN USA

HUNTER
Engineering Company

Key features at a glance

Fully Automatic

PAT. PENDING



- ✓ Same procedure for all tires and wheels
- ✓ Operator experience no longer a factor

Leverless Tool Head

PAT. PENDING



- ✓ Demounts without levers
- ✓ Prevents damage to tire and rim

“Go” Pedal Controls Progress

PAT. PENDING

- ✓ Press “Go” to make selection
- ✓ Hold “Go” to allow sequence to advance automatically
- ✓ Release “Go” to pause at any time.





Space Saving Wheel Lift

PATENTED

- ✓ Spindle lifts tire directly into position
- ✓ Built-in wheel lift reduces overall footprint



Powered Press Arms

PATENTED

- ✓ Mount virtually any tire
- ✓ Powered for maximum control



Animations & Videos

EXCLUSIVE

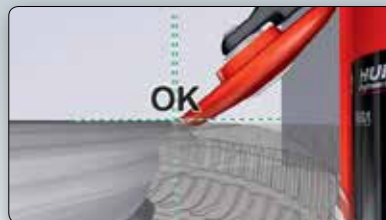

- ✓ Animations train operator "on the job"
- ✓ Video training for new users
- ✓ Video library of special procedures

PAT. PENDING

Fully automatic operation saves effort and mistakes



Bead Breaking and Demounting

1:20

The Operator's Role



✓ Load and unload the assembly



✓ Set the diameter and position valve stem/TPMS

Changing today's tires and wheels with traditional equipment requires an ever-expanding set of skills. The Revolution™ has these skills built in — simplifying the role of the technician. In short, the technician becomes a machine operator.



✓ Monitor the process



✓ Offload old tire and load new tire

Fully automatic adds safety



Position Safety

- ✓ Operator stands back and lets machine do the work



Inflation Safety

- ✓ Inflation station algorithm fills to set pressure automatically — not necessary to stand on foot pedal to inflate
- ✓ Inflation controls keep operator away from assembly



Leverless Safety

- ✓ No levers to hit operator
- ✓ Automatic press arms replace using levers for mounting



Power and Clamping Safety

- ✓ Operator's hands stay away from the assembly
- ✓ No pinch points
- ✓ No risk of rim slipping



Wheel Lift Safety

- ✓ Protects operator's back
- ✓ No need to lift heavy assemblies



TPMS Safety

- ✓ Monitors TPMS location constantly
- ✓ Won't allow tire to be mounted or demounted in unsafe TPMS location







Tire and Wheel Safety

- ✓ Automatic procedure protects rim and tire
- ✓ All rim contact, or near rim contact, is plastic



Fully automatic saves time

Operators often judge how fast they can complete a single assembly, but tire changing is an all-day process with extreme variation. Against a skilled tire technician, an automatic tire changer may be slightly slower on the simplest assemblies, but in the long run and with today's tires, the time spent changing 100 tires will be less.

OEM Fitments (2011-2014)	Percent of Fitments	Typical Conventional Time (skilled operator)	Revolution™ Time (any operator)
 Low profile (under 50 series)	51%	2:08	2:00
 Traditional	22%	1:20	1:56
 Heavy assembly (over 30" assembly)	14%	3:14	2:00
 Run flat	10%	4:06	2:07
 Large diameter (over 20" wheel)	3%	3:59	2:10
	100%	2:22 AVERAGE	2:01 AVERAGE

Cycle Time Variation

The Revolution™ handles virtually all tires in the same time.

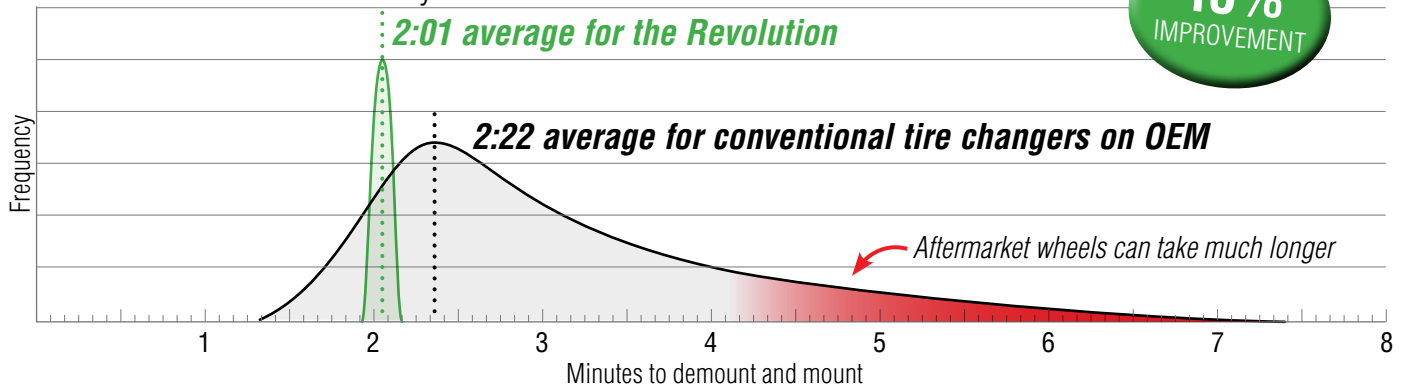

Fully automatic eliminates experience gap

The Revolution™ can elevate your tire-changing team with differing experience levels to a team of experts.

Conventional Tire Changer

*Equipment is the tool
and the technician is the tire changer.*

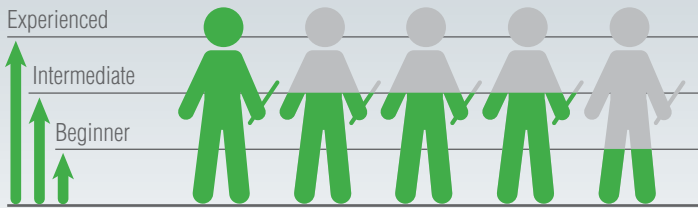

Experience makes the difference.

17 critical decisions for conventional tire changers

Bead Breaking with Shovel

1. Avoid TPMS sensor
2. Set angle and position of shovel
3. Avoid rim

Clamp

4. Inside or outside
5. Use jaw protectors or not
6. Position jaws as needed

Demount

7. Set mount head
8. TPMS sensor position
9. Use lever protector or not
10. Reloosen bottom bead

Mount

11. Position mount head
12. Over/under head
13. TPMS sensor position
14. Use press arms as needed
15. Keep tire turning with rim

Inflation

16. Inflate, then check pressure
17. Repeat as needed



Revolution™ Tire Changer

*The Revolution is the tire changer
and the technician is an equipment operator.*

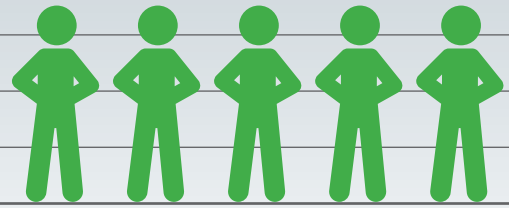

All experts in no time.

4 critical decisions for the Revolution

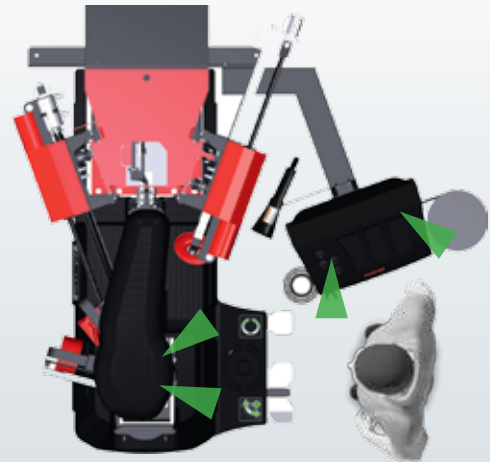

1. Select clamp size
2. Set TPMS sensor and rim diameter
3. Use press arms as needed
4. Set inflation pressure

vs.

Fully automatic simplifies training

Technique is no longer a requirement for tire changing — learn on one tire and apply same skills to all tires.

The old push here, pull there technique learned through making mistakes and busted knuckles no longer applies. On the Revolution™, the same process learned for one tire assembly applies to all tire assemblies.

Two Ways to Train:

The “Walk Me Through It” Mode

- ✓ Animation details each step
- ✓ 13 unique animations
- ✓ Can be bypassed by experienced operator



15 On-board videos

Including:

- ✓ Basic operation
- ✓ Detailed operations
- ✓ Special procedures
- ✓ Accessories



PAT. PENDING

Leverless tool head advantages

- ✓ Demounting hook automatically deploys to catch and lift bead
- ✓ No risk of lever damage to operator or rim
- ✓ Demount hook always avoids TPMS sensor — no risk of damage
- ✓ Mount head designed to work with clad, raised spoke and all unique wheel designs



PAT. PENDING

TPMS protection is automatic

Once the operator sets the diameter and positions valve stem/TPMS, the Revolution™ tracks the sensor during mounting and demounting, avoiding costly damage.

Eliminates timely “drop sensor” technique with TPMS service.



Top bead demount



Bottom bead demount



Bottom bead mount



Top bead mount

PATENTED

Powered press arms assist on demand

- ✓ Utilize Press Arms only when necessary or set up to always use them
- ✓ Press Arms adjust automatically when you set the diameter
- ✓ Press Arms power clockwise to prevent tire slippage
- ✓ Mount correctly the first revolution and protect TPMS sensors!



PAT. PENDING

Bead loosening rollers are damage free

- ✓ Bead loosening rollers work best for widest variety of tires
- ✓ Procedure loosens even the most stuck on soft sidewall tires
- ✓ No risk of TPMS damage
- ✓ No risk of rim damage



PAT. PENDING

Touchscreen interface is simple to use

The display shows the operator's current step and monitors progress. Interactions with screen are generally not required. When needed, slide out menus guide the operator through procedure.

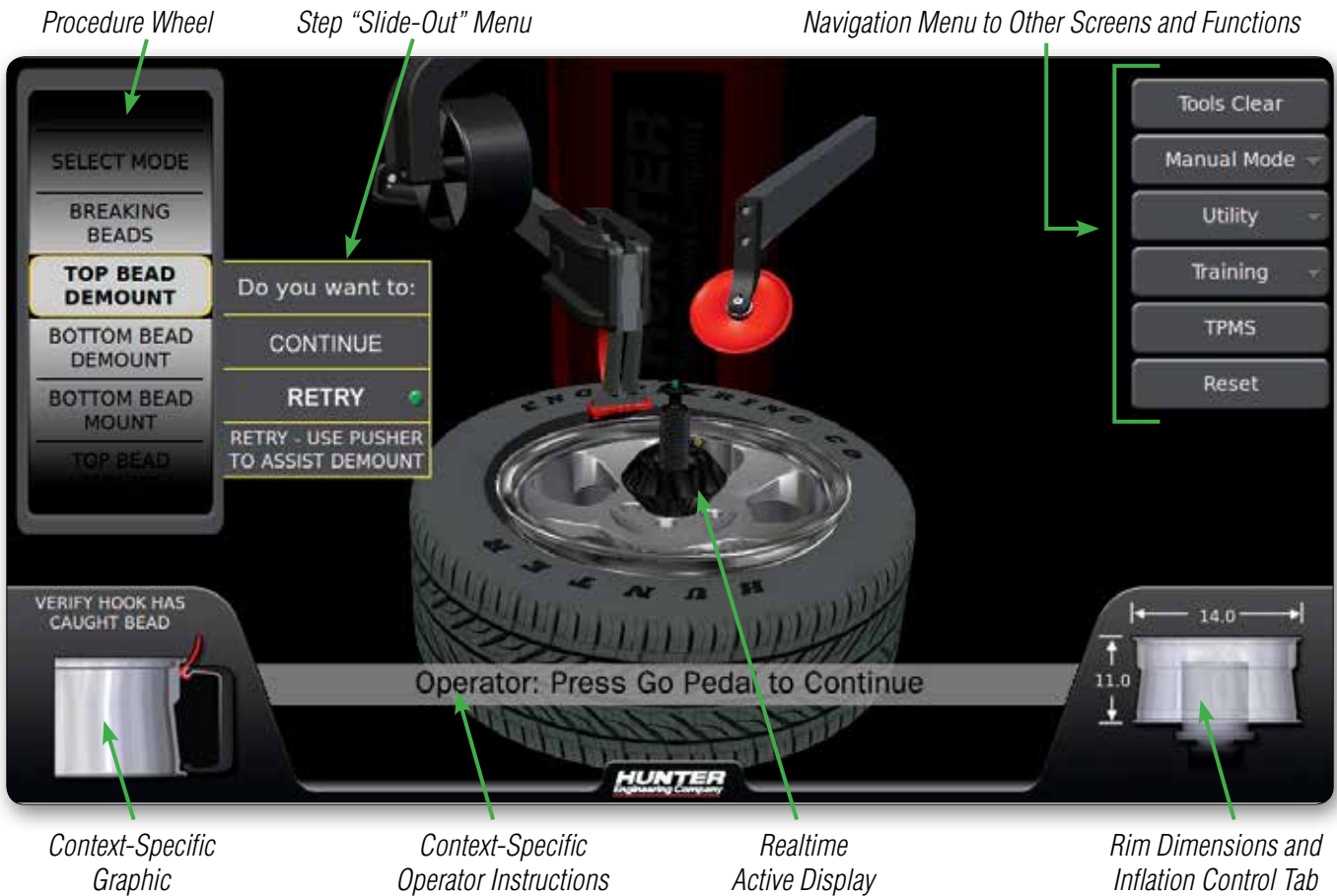

Clamping versatility

- ✓ Powerful pneumatic clamp holds wheel secure
- ✓ Center clamp design avoids clamping damage
- ✓ Three position cone handles wide variety of wheels



PAT. PENDING

Fast inflation saves time

Inflation

Inflation station automatically fills tire to desired pressure.

- ✓ 33% faster than traditional foot pedal inflation systems
- ✓ Target air pressure is adjusted on screen.
- ✓ Operator stands back from inflation process



Blast inflation

Directs large blast of air for tough bead seating.



Hydraulic operation is powerful and precise



- ✓ Hydraulic operation with filter means long durable life, much like industrial equipment
- ✓ Hydraulic operation means power and control
- ✓ Each tool can be moved quickly or slowly into position and held as needed



Reduce comebacks and do it right the first time

PAT. PENDING

Match-mounting

When used with Hunter's Road Force Touch[®], the Revolution[™] quickly and easily helps eliminate vibration problems balancers alone can't fix.

The Revolution's bead roller discs allow spinning of tire on rim, helping match-mount stiffest point on tire to low spot on rim.



PAT. PENDING

Bead Massage

The Revolution tire changer introduces an automatic bead massage sequence.

During bead massage, rollers apply force to the tire walls, assisting proper bead seating and reducing vibration concerns.

When combined with Road Force match-mounting, virtually all vibrations can be eliminated.

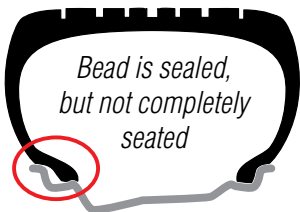

*Bead is sealed,
but not completely
seated*

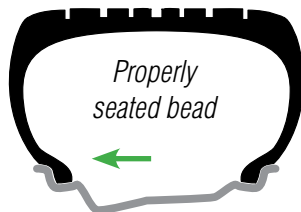

*Properly
seated bead*

50% of tire sets are significantly improved using bead massage*

* (one or more tires has 7 lbs reduction)

Standard accessories

The standard Revolution™ tire changer comes equipped to handle most tire and wheel combinations.

- A. Paste** ----- RP6-3784
- B. Paste brush** ----- RP6-1506
- C. Pin protector (2)** ----- 69-1394-2
- D. Valve Installer** ----- RP11-2020689
- E. Bead starting tool** ----- 221-659-2
- F. Valve puller** ----- RP11-2020688
- G. In-between cone** ----- 192-233-1
- H. Small polymer cone (2)** ----- 192-225-1
- I. Double sided polymer cone** ----- 192-226-1
- J. Spare roller** ----- 111-154-1
- K. Glasses** ----- 179-15-2
- L. Polymer mount head (2)** ----- 221-713-2
- M. Rubber platten cover (2)** ----- 69-1392-2



Optional accessories



Flange Plate Kit

Optional kit is ideal for plastic clad wheels or reverse wheels where maximum protection is needed. Maximum diameter 190 mm. (20-2830-3)



Dual Wheel Adaptor

Optional adaptor adds clamping capability for dual wheels, 19.5 in. wheels and other wheels with large center holes. (20-2964-1)



Camera Kit

Camera kit records tire changing. Can be used to verify correct usage and training. (20-2945-1)

Specifications



Power Requirements	208-230V, 1 phase, 60Hz, 24A, NEMA 30 amp plug, L6-30P, 5,520 watts
Air Supply Requirements	125 ± 25 psi (8.6 ± 1.7 bar)
Mount / Demount Tool	Polymer Self Inserting Leverless
Clamping Type	Center w/Quick Clamp and Cam Plate
Bead Loosening Type	Upper / Lower Roller
Match Mounting Capable	Yes
Rim Diameter Range	12 in. – 30 in. (305 mm – 762 mm)
Maximum Tire Diameter	50 in. (1,270 mm)
Maximum Wheel Width	15 in. (381 mm)
Drive	Variable up to 15 rpm CW / CCW Torque: 875 ft-lbs (1186 Nm)
Shipping Weight	1,800 lbs (816 kg)

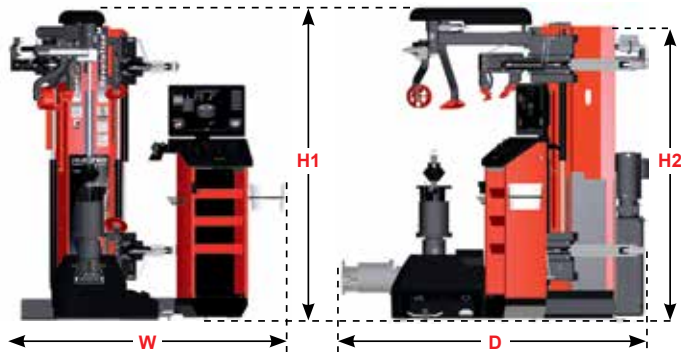

TCR1 Revolution™

Width (W)	Height (H1)	Height (H2)	Depth (D)	Weight
72 in 1,829 mm	78.5 in 1,994 mm	75.5 in 1,918 mm	78 in 1,981 mm	1,800 lbs 816 kg

Because of continuing technological advancements, specifications, models and options are subject to change without notice.



This product is listed to UL201 Garage Equipment Standard by Intertek (ETL) Testing Laboratories.

Meets national electrical code requirements for electrically powered shop equipment — 1st for an electric tire changer!

0614EH

Footprint Comparison

Revolution™

Revolution is space efficient for a premium changer.

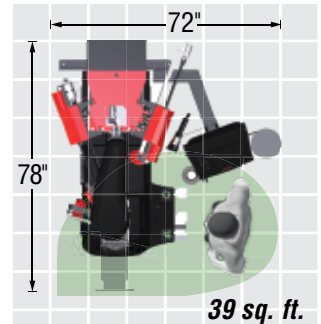

Premium Changer

Other popular premium tire changers are larger.

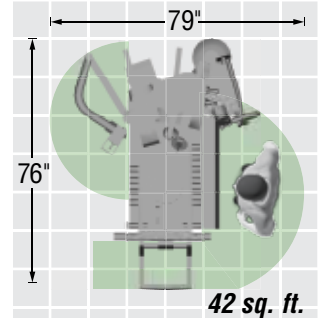

Typical Tabletop

Even simple conventional changers are larger than they appear when work area is factored.

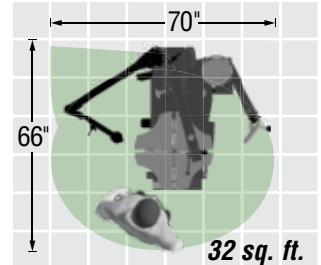

HUNTER
Engineering Company

www.hunter.com